



LINKK

We LINKK with extra care



The Manufacturer & Designer of
BUSDUCT SYSTEM



CONTENT

Introduction Product Overview

- Technical Features
- Conductor
- Epoxy
- Other Insulation Type
- Joint System
- Tap-Off Unit
- IP Busduct

Electrical Characteristics

Standard Component

Busduct Layout Design Consideration

Measurement Guideline

Illustrations Of LINKK Busduct Trunking System

Installation

General Precaution

Quality Control

Certificates

Standard & Testing

Project References

- Site Photo
- Project Photo

Continuous Busduct Monitoring System

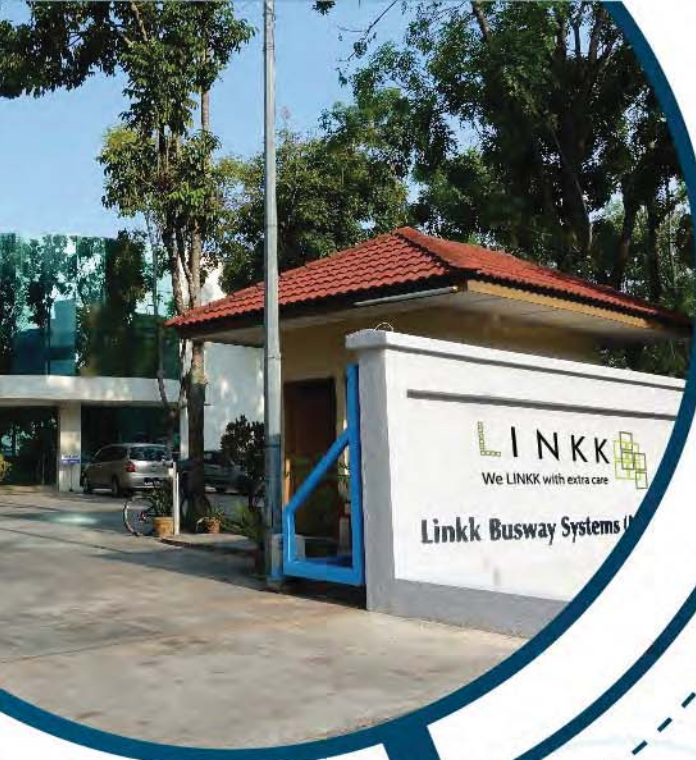

i OUR BACKGROUND

LINKK Busway Systems (M) Sdn Bhd is the leading designer and manufacturer of busduct trunking systems in Asia Pacific. Established in 1992, we have expanded our operations and now supply busduct trunking systems to over 30 countries worldwide.

Our focus on product R&D and manufacturing standards ensures that we are able to continuously improve product design and performance. In providing a product line that complies with newest international standards, we are constantly upgrading ourselves with renowned certification bodies like ASTA, KEMA, UL etc.

LINKK is determined to combine the best available product with the most comprehensive customer service in our delivery commitment to all our clients. Together with a strong track record of both private and national-level projects, this is the best testament to our reliability.

i OUR VISION

- We aim to become the leading busduct manufacturer in the world.
- To meet customer needs and provide prompt services.
- Committed to produce uniform product quality and achieve total customer satisfaction.

VISION STATEMENT

We aim to design and manufacture the most reliable busduct system and provide custom engineering to our clients.

i COMPANY QUALITY POLICY

- Total customer's satisfaction.
- Consistent product quality.
- Continual improvement.

i OUR MISSION

- Improving our quality by benchmarking our product and process.
- Expanding our range of products and services.
- Increasing our marketing activities worldwide.
- Investing in R&D.
- Developing and enhancing our human resources.

TECHNICAL FEATURES

LINKK is a busduct system developed by **LINKK Busway Systems (M) Sdn Bhd**. It is designed for commercial and industrial electrical distributions.

Standards

LINKK systems are tested and certified by **KEMA, ASTA** and **UL** to comply with:

- BS 5486, Part 2, 1990
- IEC 61439 Part 1:2011 (Updated from IEC 60439 Part 1:2005)
- IEC 61439 Part 6:2012 (For Busbar Trunking Systems - BUSWAYS)
- IEC 60331
- IEC 60529

Busduct types

LINKK is light weight, low impedance, non-ventilated, naturally cooled and totally enclosed within the steel or aluminium housing for protection against mechanical damages and dust accumulation. It consists copper bars with purity >99.95%, or aluminium bars with conductivity >61%.

- Feeder and plug-in type busducts.
- Indoor protection IP40/IP42/IP54/IP55/IP65/IP66.
- Outdoor protection IP66/IP67/IP68.
- Tap-off units(plug-in) protection IP2X/IP40/IP42/IP54/IP55.
- Fire retardant protection conforms to IEC 60331 and CNS 14286.

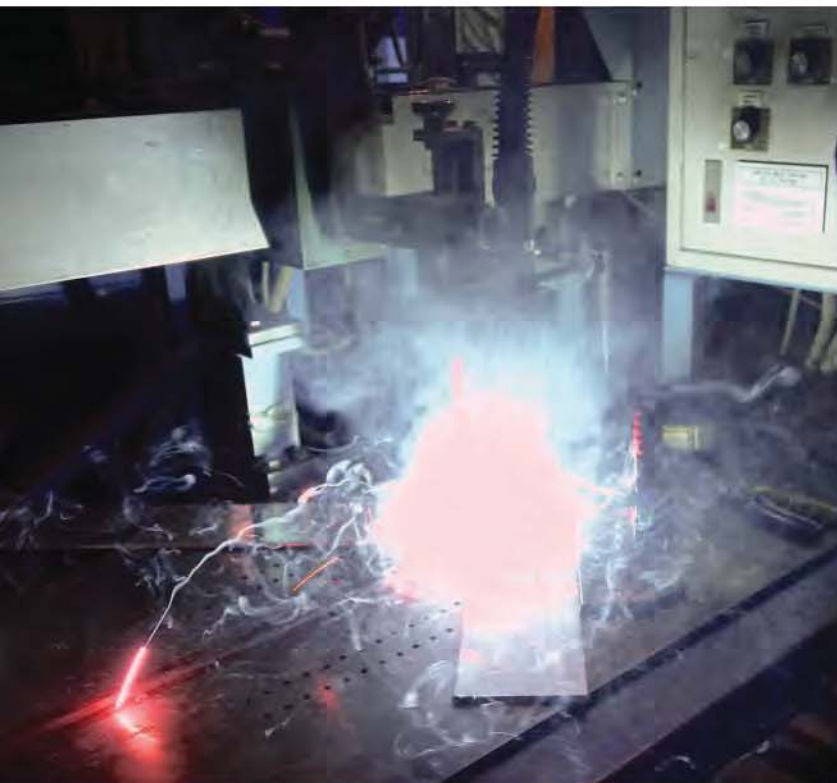

System

Our busduct can be applied to different system configuration as below:

- 3P3W
- 3P3W+50%E
- 3P4W
- 3P4W+50%E
- 3P4W+100%E
- 3P4W(200%N)
- 3P4W(200%N)+50%E
- 3P4W(50%N)
- 3P4W(50%N)+50%E

Other type of configuration can be designed upon special request from customer.

Unique features

The latest LINKK systems are incorporated with many improved designs/features to provide cost effective solutions for building a power system:

- Higher efficiency in power transmission/distribution.
- Lower installation cost.
- Easier maintenance.
- More compact and suitable for tight plan room space.
- Higher reliability.
- Longer life span.
- Higher flexibility for future expansion.
- Extremely flexible in installation.

LINKK CONDUCTOR

All LINKK conductor are high density and conductivity >100% IACS with a minimum purity of 99.95%. It is fabricated through a sophisticated thermal compression process developed by LINKK which involves application of tremendous heat under high pressure. It can be fully tinned or silver-plated with epoxy powder coated as insulation giving 100% water and chemical resistance. Optional specifications can be designed and fabricated to customer requirement.

Advantages of using LINKK conductor are:

- High electrical conductivity
- Low impurity
- Excellent fatigue resistance
- High thermal conductivity
- High mechanical strength
- Outstanding corrosion resistant



LINKK EPOXY

LINKK Epoxy System is the 3rd generation with own formulation. The class H-180°C standard epoxy coating provides 100% water proofing and high mechanical strength. It has been tested in accordance with IEC 61439-6 and BS 5486.

Advantages of using epoxy coating as insulations are:

- Design to withstand glitch and spikes in electrical system.
- Design to cater for expansion and contraction during peak and off-peak hours.
- Capable of withstanding heat shock.
- High reliability under static conditions.
- High mechanical strength against impact.
- High thermal conductivity.
- Water and chemical resistant.

OTHER INSULATION TYPE

Besides epoxy insulation, we also provide other classes of insulation as below:

- Class B- It consists of two layers of Mylar(Polyester Film) which resists temperature up to 130°C.
- Fire Rated - It consists of 1 layer of mylar(polyester film) and 2 layers of Mica (mineral silicate sheet) which resist temperature up to 900°C.

JOINT SYSTEM

In order to overcome extreme rugged conditions at site, the new LINKK joint has been designed precisely and manufactured using the highest quality of materials to minimize all possible problems and enhance system performance. This special design provides outstanding features as follows:

- Incorporates a 5mm thermal expansion and movement at every joint.
- Allow $\pm 15\text{mm}$ of lateral adjustment(total 30mm) to correct site measurement inaccuracy.
- Able to tilt an angle of $\pm 5^\circ$ (total 10° along single axis).
- Bolt and nuts can be stainless steel, galvanized or chromed black high tensile steel.
- Degree of protection of IP40/IP54/IP66/IP67/IP68.
- Easy installation and removal of any joint in a run without disturbing the two adjacent busduct sections.
- Water/chemical resistance BMC insulation plates.

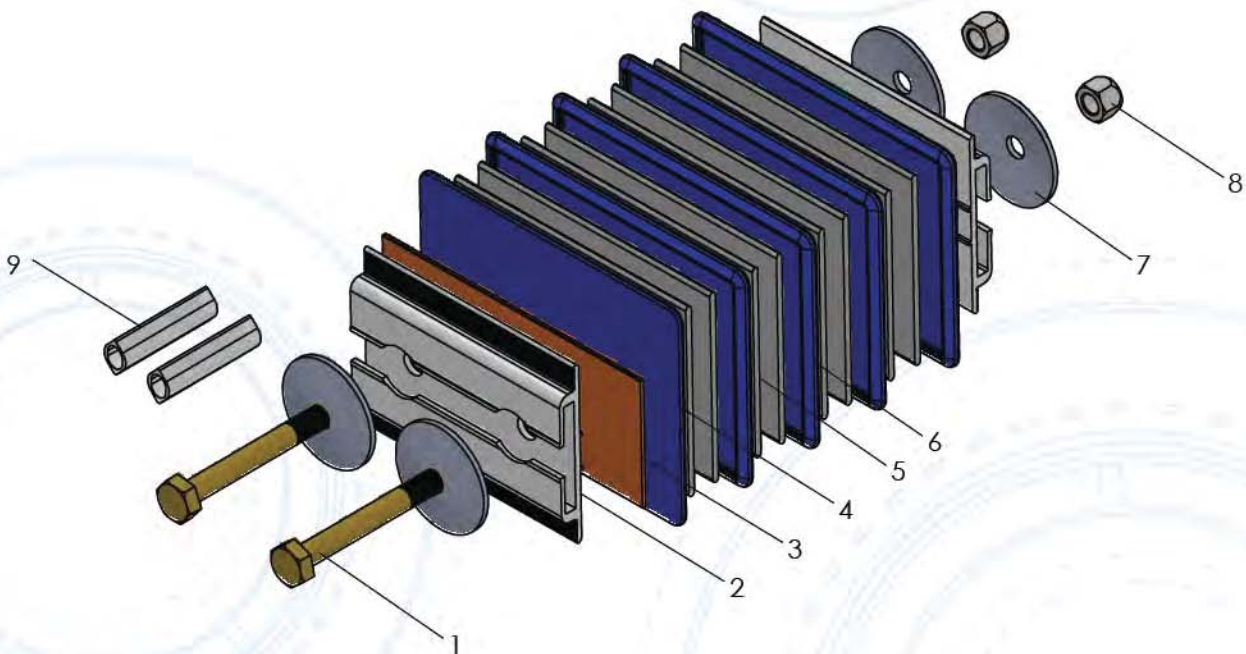

1. Joint bolt
2. Joint backing plate
3. Joint Earth Bar
4. Joint end insulator
5. Joint conductor bar

6. Joint phase insulator
7. Belleville disc
8. Nylon lock nut
9. Fiber tube

TAP-OFF UNITS(PLUG-IN UNITS)

Tap-off unit with moulded case circuit breaker or fused-switch breakers of various current ratings are available to cater for most installations. Maximum 5 tap-off units per side can be installed, total 10 nos per length of 3m busduct subject to the size of MCCBs.

- All tap-off unit are designed with interlocking safety features to prevent removal when tap-off unit in 'On' position.
- When tap-off unit cover is open, automatically MCCB cannot be turned 'On'

On/off handle design

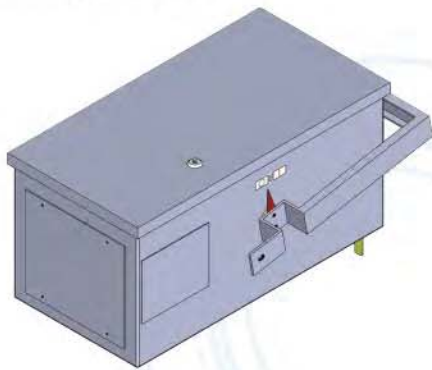

Bottom entry cable design

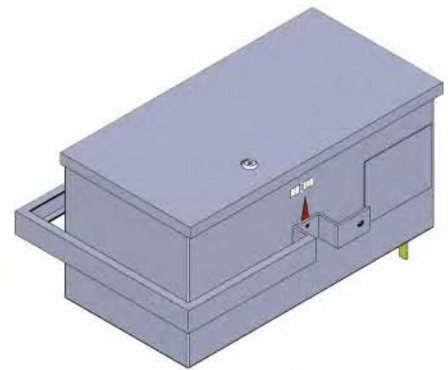

Top entry cable design

Rotary handle design

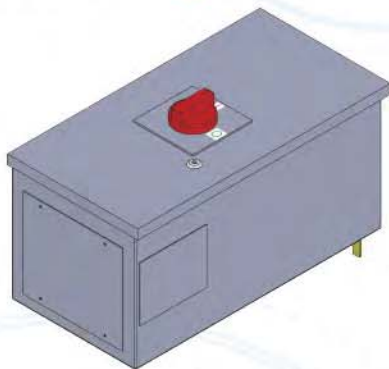

Bottom entry cable design

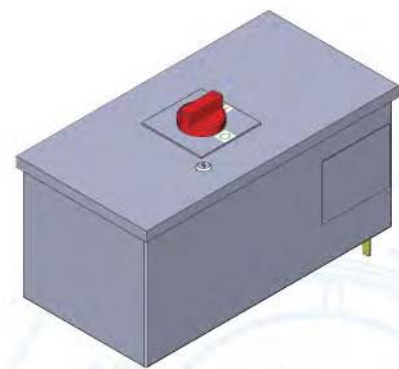

Top entry cable design

Outlet design



Bottom entry cable design



Top entry cable design

IP BUSDUCT

IP 54 to IP66 (Indoor)

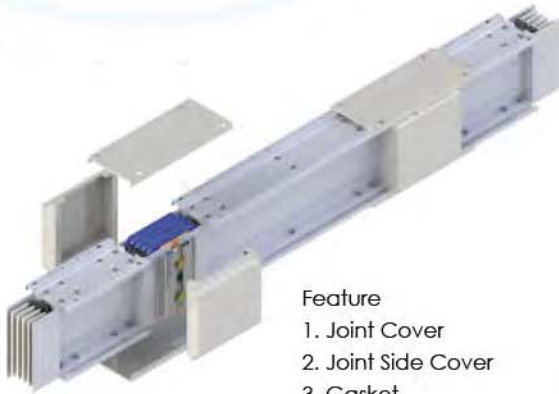

- Feature
1. Joint Cover
 2. Joint Side Cover
 3. Gasket
 4. Silicon

IP 66 (Outdoor)

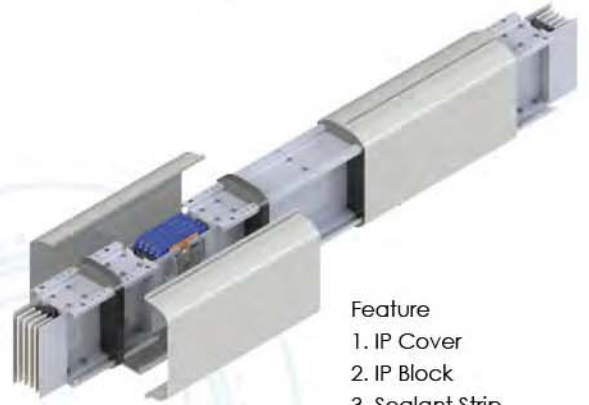

- Feature
1. IP Cover
 2. IP Block
 3. Sealant Strip

* IP 42 does not have Joint Side Cover

IP Interchange Busduct

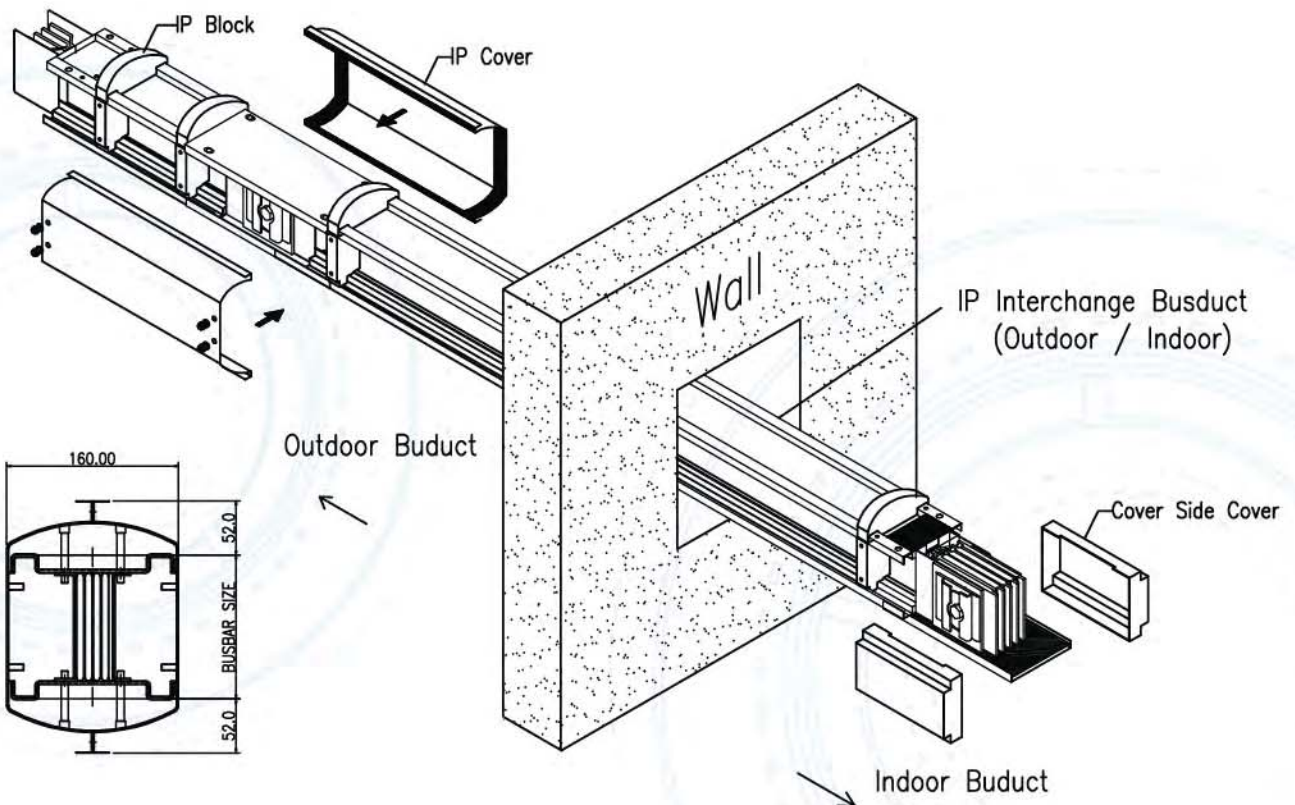

IP (INGRESS PROTECTION RATING GUIDE)

SOLIDS

1



Protection against a solid object greater than 50mm such as a hand.

2



Protection against a solid object greater than 12.5mm such as a finger.

3



Protection against a solid object greater than 2.5mm such as a screwdriver.

4



Protection against a solid object greater than 1mm such as a wire.

5



Dust Protected. Limited ingress of dust permitted. Will not interfere with operation of the equipment. Two to eight hours.

6



Dust tight. No ingress of dust. Two to eight hours.

WATER

1



Protection against vertically falling drops of water. Limited ingress permitted.

2



Protection against vertically falling drops of water with enclosure tilted up to 15 degrees from the vertical. Limited ingress permitted.

3



Protection against sprays of water up to 60 degrees from the vertical. Limited ingress permitted for three minutes.

4



Protection against splashed from all directions. Limited ingress permitted.

5



Protection against jets of water. Limited ingress permitted.

6



Water from heavy seas or water projected in powerful jets shall not enter the enclosure in harmful quantities.

7

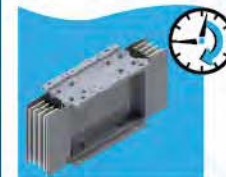

Protection against the effects of immersion in water between 15cm and 1m for 30 minutes

8



Protection against the effects of immersion in water under pressure for long periods.

Rating Example:

IP65

INGRESS PROTECTION

CONFIGURATION OF LINKK BUSWAY TRUNKING

Electrical Characteristics For Copper & Aluminium in 50Hz

Copper - 50Hz

Rated Current (A)	Impedance ($10^{-6} \Omega/m$)			Line to line voltage drop in (mV/m) at rated current and various power factors									
	R	X	Z	1.00	0.90	0.80	0.70	0.60	0.50	0.40	0.30	0.20	0.10
400	124.94	98.67	159.20	86.56	107.70	110.27	109.41	106.63	102.48	97.28	91.18	84.29	76.67
630	74.90	93.31	119.65	81.73	117.94	126.48	129.92	130.49	129.04	126.01	121.65	116.11	109.48
800	54.66	75.48	93.19	75.74	113.75	123.34	127.71	129.11	128.45	126.15	122.49	117.62	111.64
1000	45.24	25.40	51.88	78.36	89.70	89.08	86.27	82.21	77.28	71.66	65.48	58.78	51.61
1250	40.08	19.38	44.52	86.78	96.39	94.60	90.71	85.63	79.73	73.17	66.06	58.47	50.43
1600	26.81	15.35	30.89	74.30	85.41	84.96	82.39	78.61	73.99	68.71	62.87	56.54	49.76
2000	22.98	12.10	25.97	79.61	89.92	88.83	85.66	81.30	76.10	70.26	63.87	56.99	49.67
2500	18.38	10.30	21.07	79.59	91.07	90.43	87.56	83.43	78.42	72.71	66.42	59.62	52.34
3200	13.79	7.21	15.56	76.43	86.21	85.12	82.04	77.83	72.82	67.20	61.05	54.44	47.40
4000	11.28	4.67	12.21	78.15	84.44	81.93	77.81	72.77	67.10	60.91	54.31	47.33	40.01
5000	9.57	3.75	10.28	82.88	88.75	85.79	81.21	75.71	69.56	62.92	55.84	48.40	40.60

Aluminium - 50Hz

Rated Current (A)	Impedance ($10^{-6} \Omega/m$)			Line to line voltage drop in (mV/m) at rated current and various power factors									
	R	X	Z	1.00	0.90	0.80	0.70	0.60	0.50	0.40	0.30	0.20	0.10
400	134.25	82.12	157.37	93.01	108.51	108.55	105.74	101.32	95.78	89.35	82.18	74.35	65.91
630	101.19	62.42	118.89	110.42	129.07	129.20	125.93	120.74	114.20	106.59	98.10	88.82	78.81
800	73.80	20.16	76.50	102.26	104.21	98.57	91.53	83.70	75.32	66.51	57.33	47.82	38.02
1000	52.50	15.68	54.79	90.93	93.68	89.04	83.05	76.29	68.99	61.26	53.19	44.80	36.12
1250	47.33	11.26	48.65	102.47	102.85	96.61	89.14	80.99	72.35	63.33	54.00	44.38	34.50
1600	35.75	9.76	37.06	99.07	100.96	95.49	88.67	81.08	72.96	64.42	55.52	46.32	36.82
2000	29.87	7.97	30.92	103.47	105.16	99.34	92.15	84.17	75.65	66.69	57.38	47.75	37.82
2500	23.04	6.75	24.01	99.77	102.53	97.35	90.71	83.24	75.20	66.69	57.81	48.59	39.06
3200	18.46	5.02	19.13	102.32	104.21	98.55	91.49	83.65	75.25	66.43	57.24	47.72	37.92
4000	11.92	2.32	12.14	82.58	81.33	75.71	69.29	62.41	55.21	47.77	40.11	32.27	24.25
5000	7.85	1.24	7.95	67.98	65.87	60.83	55.26	49.38	43.29	37.04	30.64	24.12	17.48

Note: For the 60Hz calculation, divide the reactance (X) by 0.83. And the resistance (R) remains unchanged due to the negligible difference in frequency.

Voltage Drop Calculation

As per IEC 61439-6:2012

$$DV = k \times (\sqrt{3}) \times I (R \cos\phi + X \sin\phi)$$

where,

- DV = Line to line voltage drop per meter (to be calculated)
- I = Load current
- cos ϕ = Load Power Factor
- sin ϕ = Sq. Root (1 - Cos² ϕ)
- R = Resistance
- X = Reactance
- k = The load distribution factor
- * 1 if the load is centred at the end of the BT run;
- * (n+1) / (2 x n) if the load is uniformly spread between n branches (where n = no. of TOU)

LINKK STANDARD COMPONENTS

Feeder Busduct

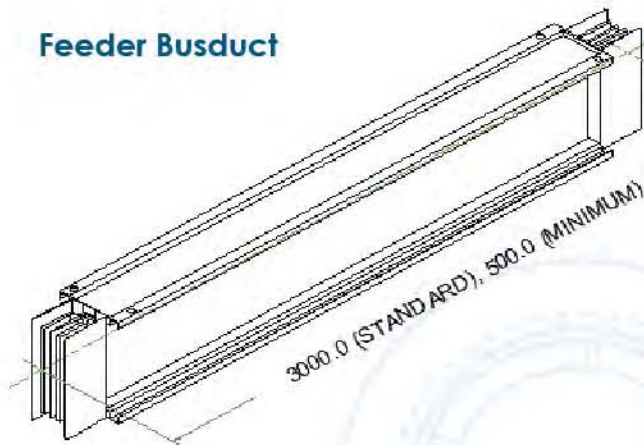

Plug-In Busduct

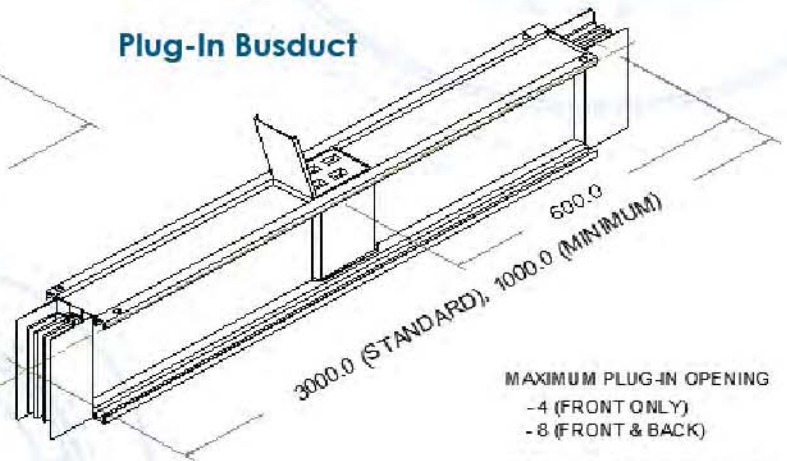

MAXIMUM PLUG-IN OPENING
- 4 (FRONT ONLY)
- 8 (FRONT & BACK)

PLUG-IN OPENING INTERVAL
- 600mm (STANDARD)

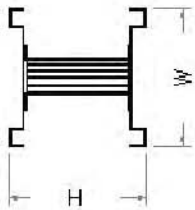

[Fig.L1-1]

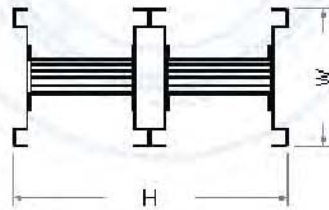

[Fig.L1-2]

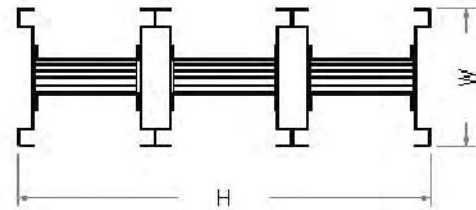

[Fig.L1-3]

Copper

Ampere (A)	W	x	H	Weight (kg/m)		Fig.
				3P4W	3P4W+50%E	
400	150	x	74	14	15	L1-1
630	150	x	64	16	17	L1-1
800	150	x	74	17	18	L1-1
1000	150	x	94	21.5	23	L1-1
1250	150	x	104	25	27	L1-1
1600	150	x	124	28.5	31	L1-1
2000	150	x	188	42.5	46	L1-2
2500	150	x	218	51	55	L1-2
3200	150	x	288	71	77	L1-2
4000	150	x	348	59.5	92	L1-2
5000	150	x	468	129	140	L1-2

Aluminium

Ampere (A)	W	x	H	Weight (kg/m)		Fig.
				3P4W	3P4W+50%E	
400	150	x	59	9.7	10	L1-1
630	150	x	74	10.6	11	L1-1
800	150	x	84	11.5	12	L1-1
1000	150	x	114	14.3	15	L1-1
1250	150	x	144	17	18	L1-1
1600	150	x	184	21.7	23	L1-1
2000	150	x	234	26.3	28	L1-1
2500	150	x	288	24	36	L1-2
3200	150	x	368	43.5	46	L1-2
4000	150	x	468	52.5	56	L1-2
5000	150	x	582	71	75	L1-3

Flange End

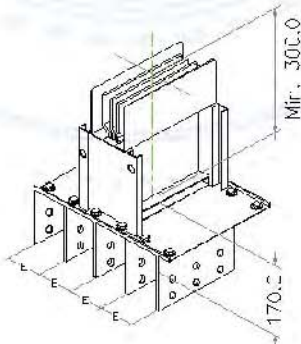

End Feed Cable Box

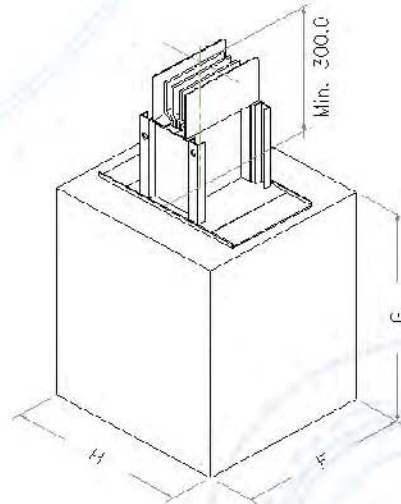

Mounting Cut Out

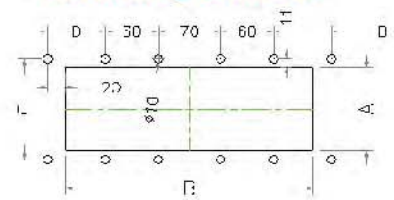

[Fig.L2-1]

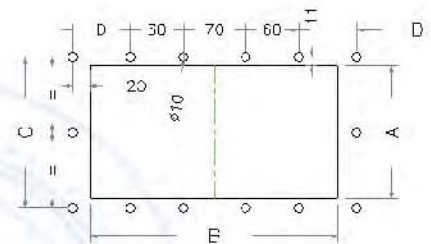

[Fig.L2-2]

Copper

Ampere (A)	Mounting Cut Out (mm)				Interval (mm)	End Feed Box Size (mm)			Fig.
	A	B	C	D		F	G	H	
400	50	280	72	65	80	330	500	400	L2-1
630	40		62						
800	50		72						
1000	70		92						
1250	80		102						
1600	100	122	95	100	400	650	450	L2-2	
2000	164	186							
2500	194	216							
3200	264	286							
4000	324	346							
5000	444	466			500				

Aluminium

Ampere (A)	Mounting Cut Out (mm)				Interval (mm)	End Feed Box Size (mm)			Fig.
	A	B	C	D		F	G	H	
400	35	280	57	65	80	330	500	400	L2-1
630	50		72						
800	60		82						
1000	90		112						
1250	120		142						
1600	160	340	182	95	100	400	650	450	L2-2
2000	210		232						
2500	264		286						
3200	344		366						
4000	444		466						
5000	558	420			600	700			

Flatwise Elbow

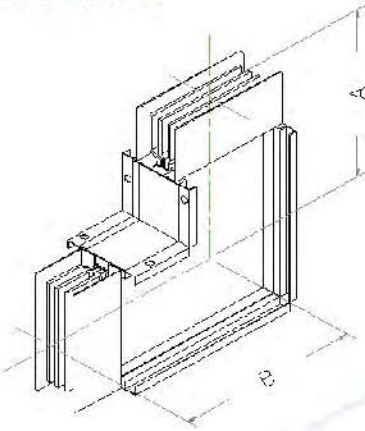

Ampere (A)	Copper	Aluminium
	Standard (mm) A x B	
400	330 x 330	330 x 330
630	330 x 330	330 x 330
800	330 x 330	340 x 340
1000	340 x 340	355 x 355
1250	350 x 350	370 x 370
1600	360 x 360	390 x 390
2000	390 x 390	415 x 415
2500	405 x 405	440 x 440
3200	440 x 440	480 x 480
4000	470 x 470	530 x 530
5000	530 x 530	590 x 590

Flatwise Offset

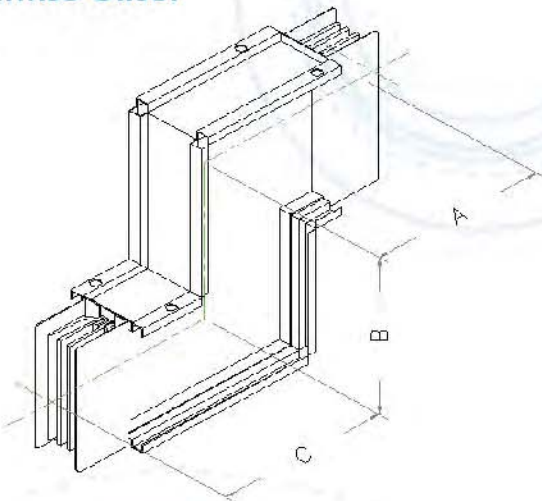

Ampere (A)	Copper	Aluminium
	Standard (mm) A x B x C	
400	330 x 300 x 330	330 x 300 x 330
630	330 x 300 x 330	330 x 300 x 330
800	330 x 300 x 330	340 x 300 x 340
1000	340 x 300 x 340	355 x 300 x 355
1250	350 x 300 x 350	370 x 300 x 370
1600	360 x 300 x 360	390 x 300 x 390
2000	390 x 300 x 390	415 x 300 x 415
2500	405 x 300 x 405	440 x 300 x 440
3200	440 x 300 x 440	480 x 300 x 480
4000	470 x 300 x 470	530 x 300 x 530
5000	530 x 300 x 530	590 x 300 x 590

Flatwise Tee

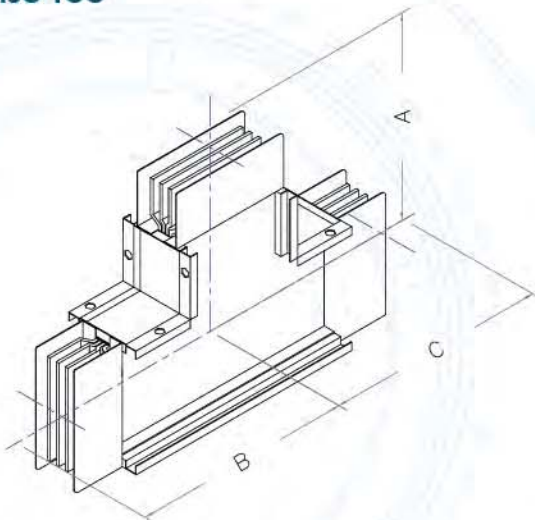

Ampere (A)	Copper	Aluminium
	Standard (mm) A x B x C	
400	330 x 330 x 330	330 x 330 x 330
630	330 x 330 x 330	330 x 330 x 330
800	330 x 330 x 330	340 x 340 x 340
1000	340 x 340 x 340	355 x 355 x 355
1250	350 x 350 x 350	370 x 370 x 370
1600	360 x 360 x 360	390 x 390 x 390
2000	390 x 390 x 390	415 x 415 x 415
2500	405 x 405 x 405	440 x 440 x 440
3200	440 x 440 x 440	480 x 480 x 480
4000	470 x 470 x 470	530 x 530 x 530
5000	530 x 530 x 530	590 x 590 x 590

Combination Elbow

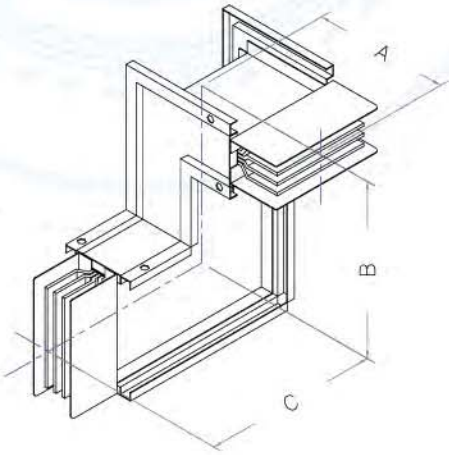

Ampere (A)	Copper	Aluminium
	Standard (mm) A x B x C	
400	310 x 300 x 330	310 x 300 x 330
630	310 x 300 x 330	310 x 300 x 330
800	310 x 300 x 330	310 x 300 x 340
1000	310 x 300 x 340	310 x 300 x 355
1250	310 x 300 x 350	310 x 300 x 370
1600	310 x 300 x 360	310 x 300 x 390
2000	310 x 300 x 390	310 x 300 x 415
2500	310 x 300 x 405	310 x 300 x 440
3200	310 x 300 x 440	310 x 300 x 480
4000	310 x 350 x 470	310 x 350 x 530
5000	310 x 350 x 530	310 x 350 x 590

End Cover

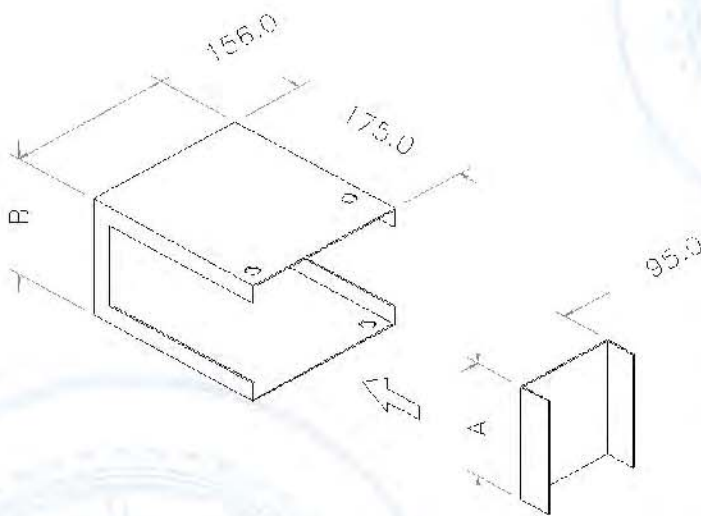

Ampere (A)	Copper	Aluminium
	Standard (mm) A x B	
400	75 x 80	60 x 65
630	65 x 70	75 x 80
800	75 x 80	85 x 90
1000	90 x 95	115 x 120
1250	105 x 110	145 x 150
1600	125 x 130	185 x 190
2000	190 x 195	235 x 240
2500	220 x 225	290 x 295
3200	290 x 295	370 x 375
4000	350 x 355	470 x 475
5000	470 x 475	585 x 590

Wall Flange

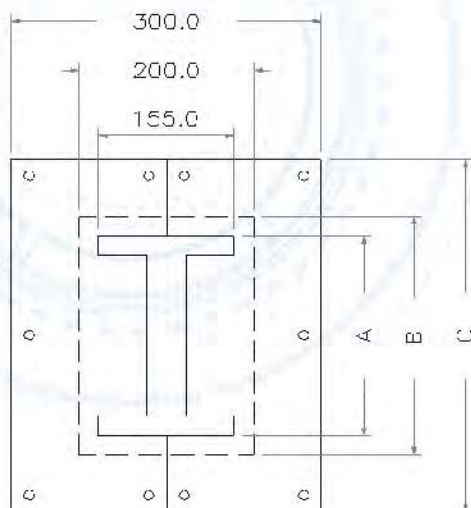

Ampere (A)	Copper	Aluminium
	Standard (mm) A x B x C	
400	85 x 130 x 170	70 x 115 x 165
630	75 x 120 x 160	85 x 130 x 180
800	85 x 130 x 170	95 x 140 x 190
1000	100 x 145 x 185	125 x 170 x 220
1250	115 x 160 x 200	155 x 200 x 250
1600	135 x 180 x 220	195 x 240 x 290
2000	200 x 245 x 285	245 x 290 x 340
2500	230 x 275 x 315	300 x 345 x 395
3200	300 x 345 x 385	380 x 425 x 475
4000	360 x 405 x 445	480 x 525 x 575
5000	480 x 525 x 565	595 x 640 x 690

Edgewise Elbow

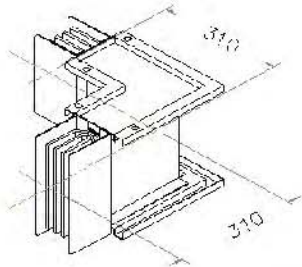

Edgewise Tee

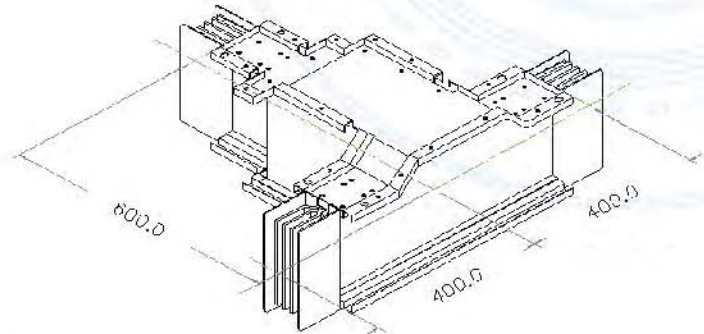

Phase Transposition Unit

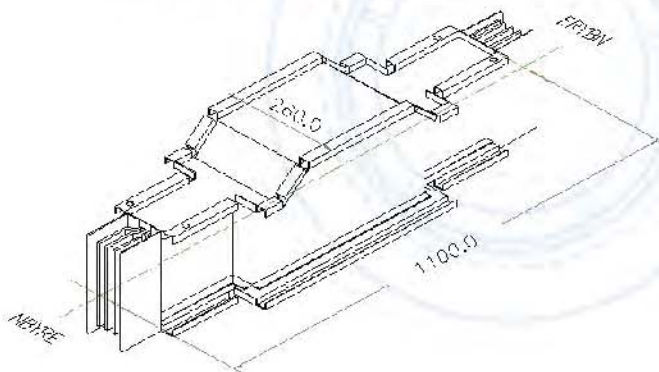

Edgewise Offset

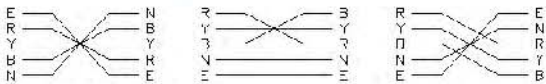
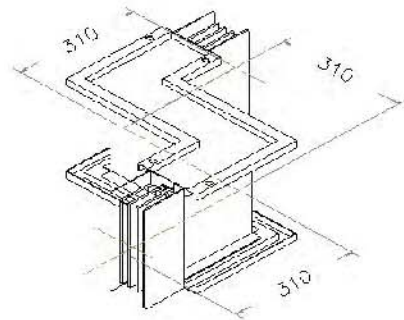

Reducer

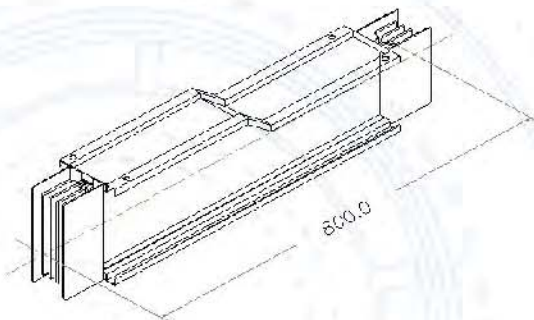

Expansion Unit

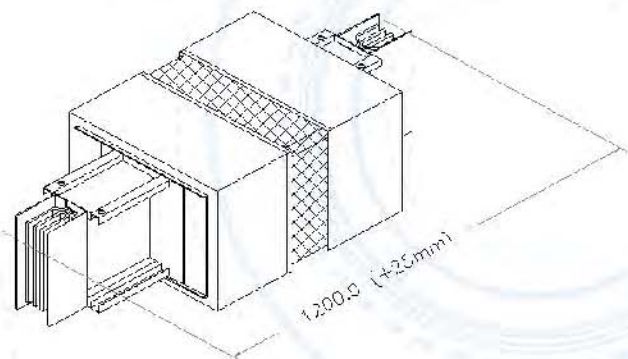

- Noted:**
- * Edgewise Elbow = Horizontal Elbow
 - * Flatwise Elbow = Vertical Elbow
 - * Refer to manufacturer for SPECIAL degree Elbow

Tap-Off Unit

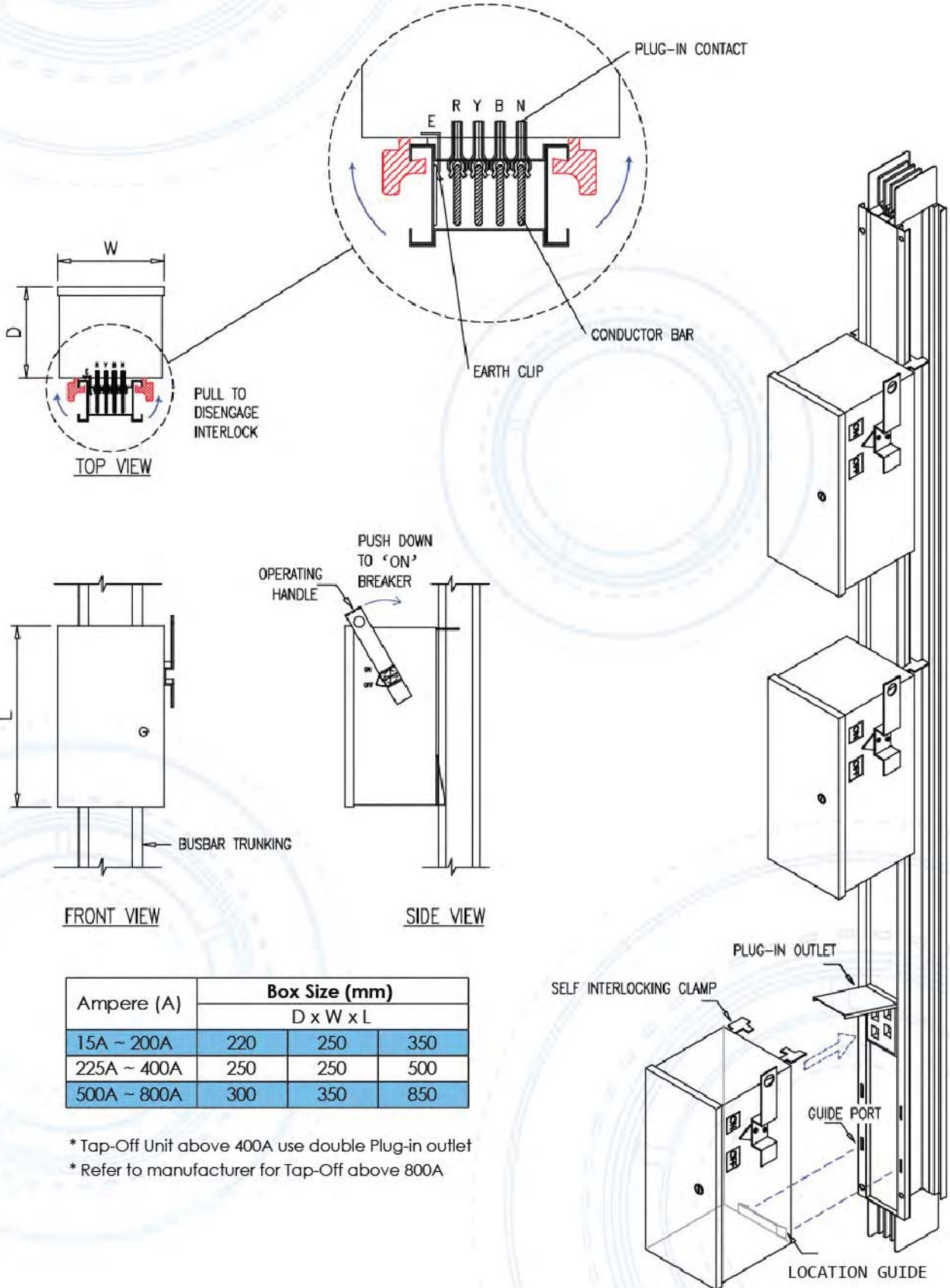

Ampere (A)	Box Size (mm)		
	D x W x L		
15A ~ 200A	220	250	350
225A ~ 400A	250	250	500
500A ~ 800A	300	350	850

- * Tap-Off Unit above 400A use double Plug-in outlet
- * Refer to manufacturer for Tap-Off above 800A

Horizontal Support (Clip)

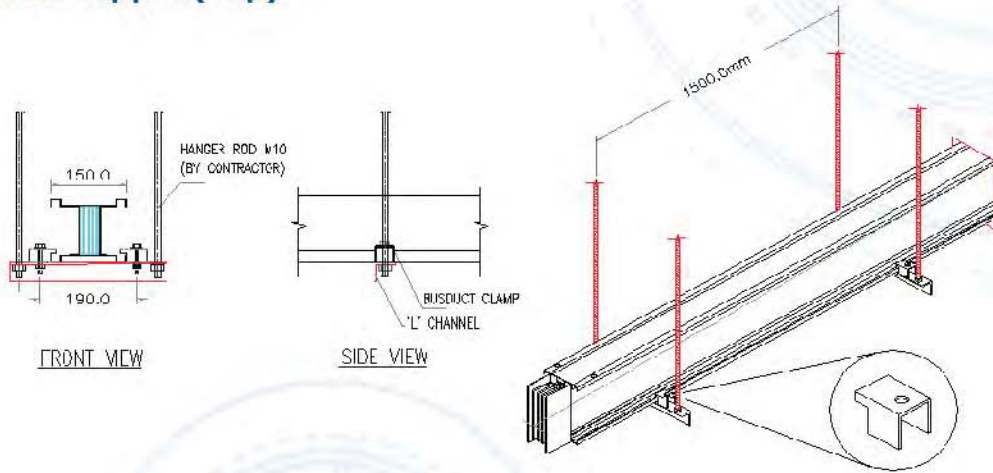

Vertical Fixed Support

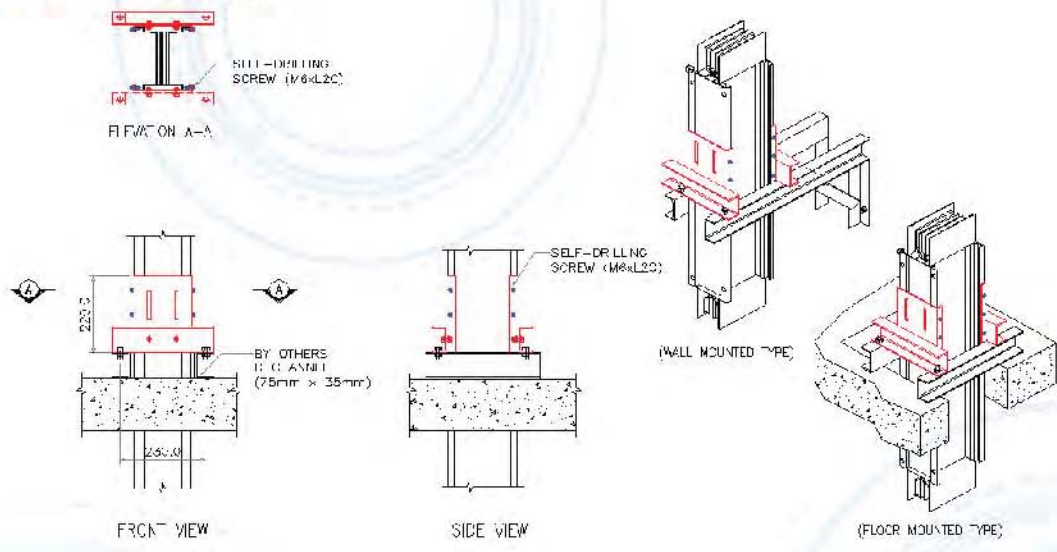

Vertical Spring Hanger

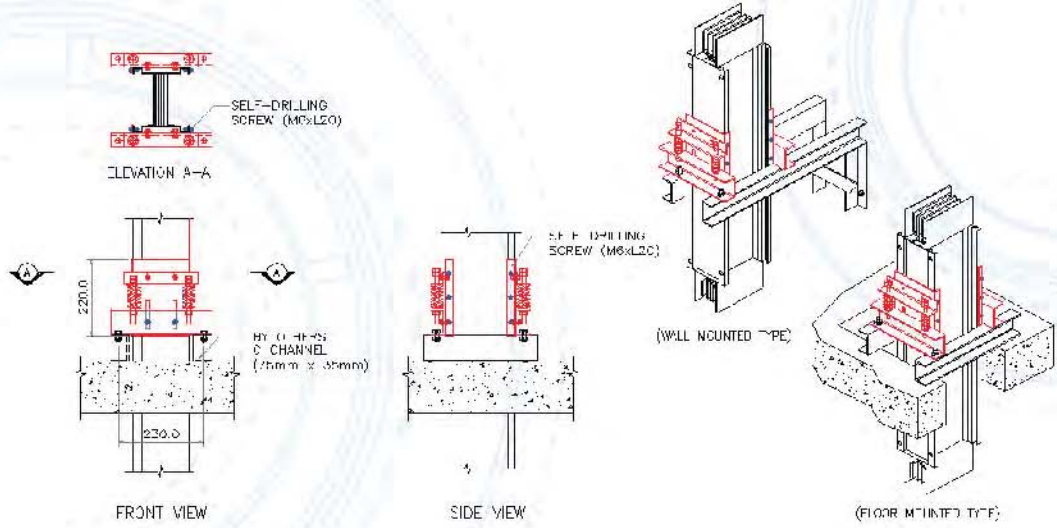

BUSDUCT LAYOUT DESIGN CONSIDERATION

Minimum Distance From Beam

(BUSDUCT UNDER BEAM WITHOUT JOINT POINT)

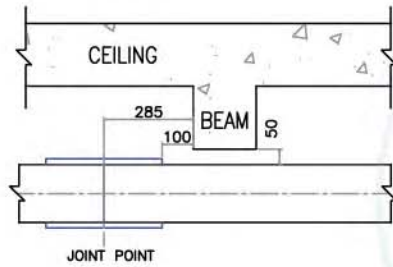
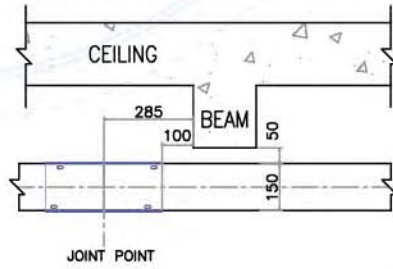

(BUSDUCT UNDER BEAM WITH JOINT POINT)

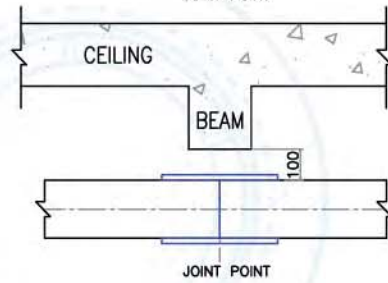
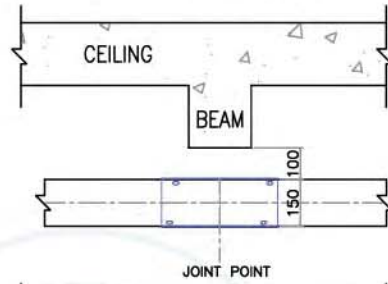

Minimum Distance From Wall

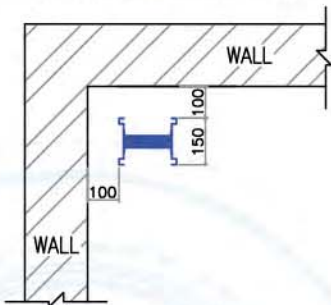

Minimum Distance From Wall And Ceiling

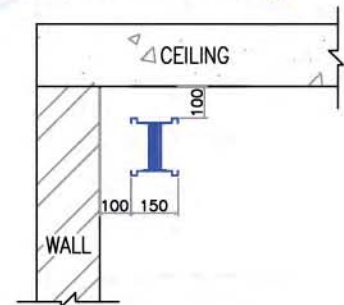
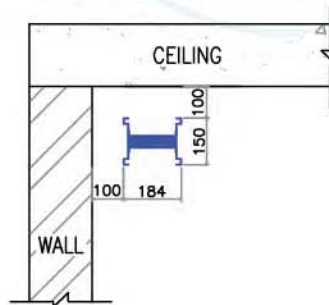

Busduct Jointing Point Through Wall Opening Installation (Joints Should Not Be Installed Inside Walls)

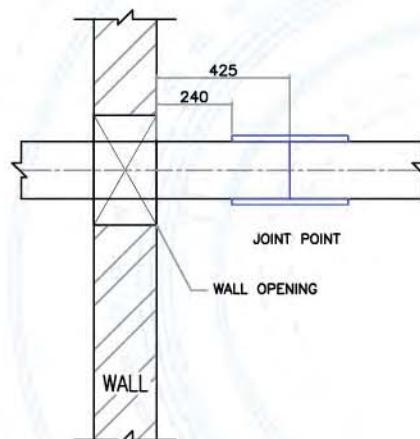
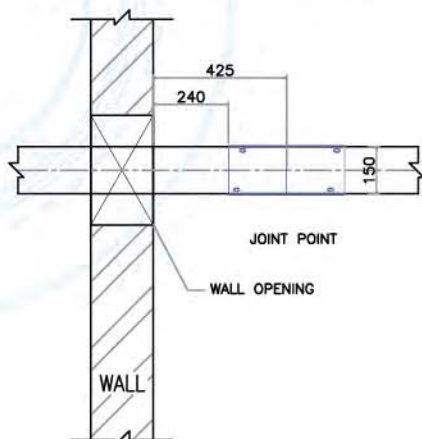

BUSDUCT LAYOUT DESIGN CONSIDERATION

Minimum Clearance Of Vertical Feeder Busduct Joints Side By Side

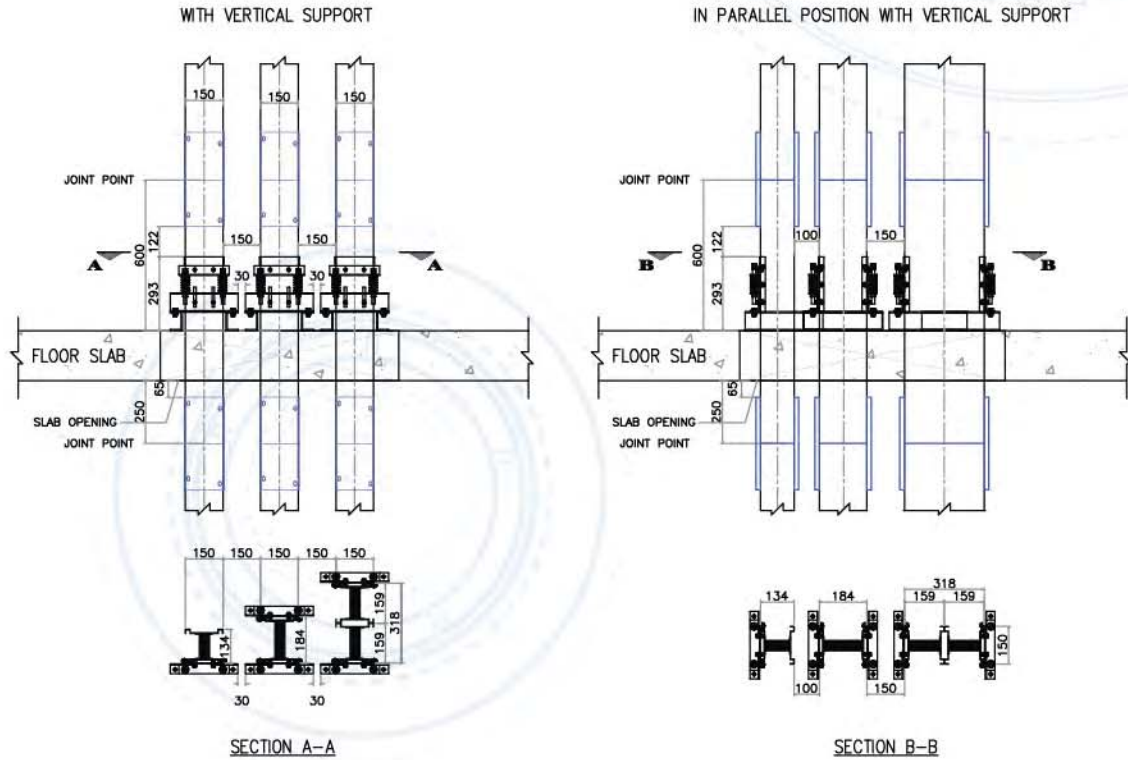

Minimum Clearance Of Plug-In Busducts With Tap-Off Unit Installed Flat In Parallel Position

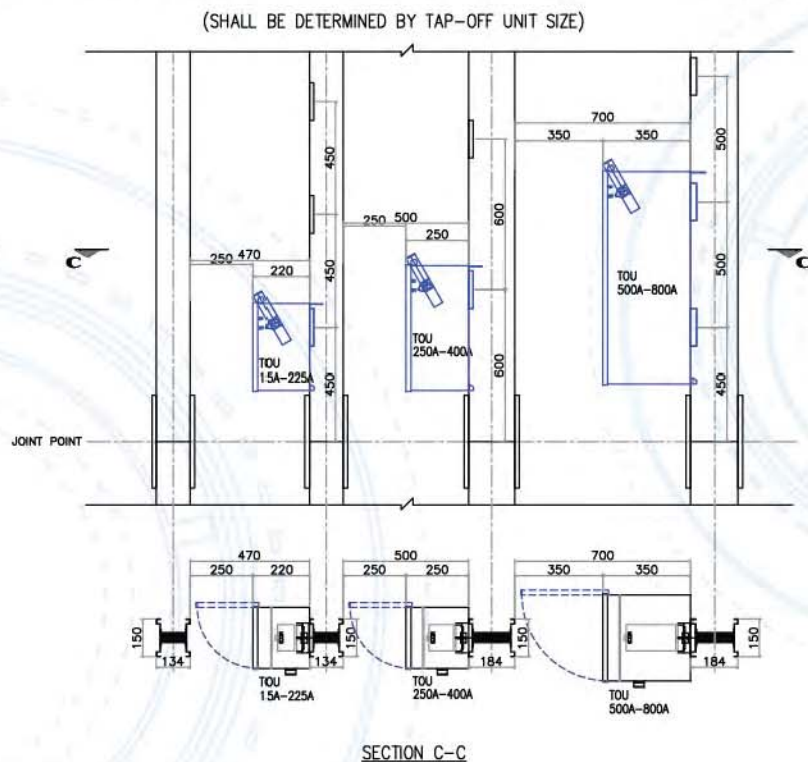

MEASUREMENT GUIDELINE

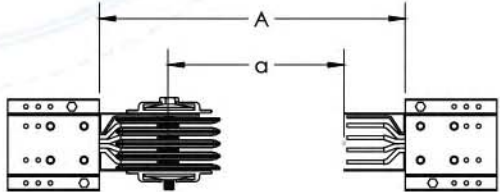
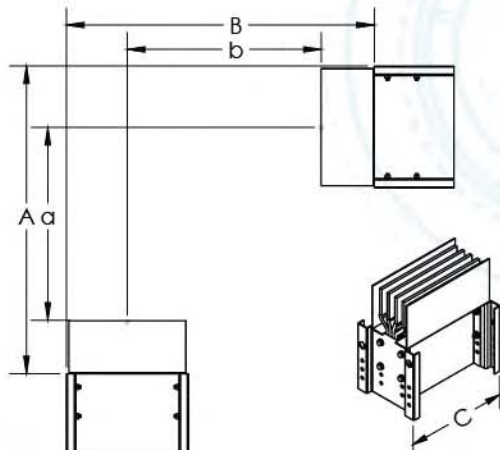
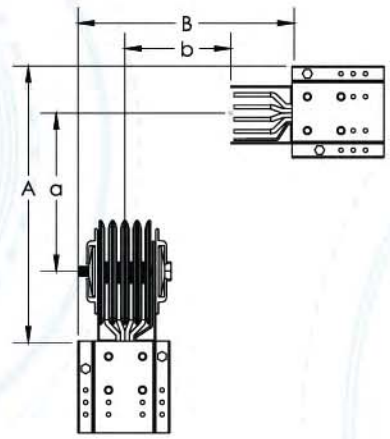
<p>Feeder</p> 	<p>$\alpha = A - 115\text{mm} - 115\text{mm}$</p> <p>Example: A=800mm</p> <p>$\alpha = 800 - 115 - 115$ $\alpha = 570\text{mm}$</p>
<p>Flatwise Elbow</p> 	<p>$\alpha = A - 115\text{mm} - C/2$</p> <p>$b = B - 115\text{mm} - C/2$</p> <p>Example: A=800mm, B=1000mm, C=180mm</p> <p>$\alpha = 800 - 115 - 180/2$ $\alpha = 595\text{mm}$</p> <p>$b = 1000 - 115 - 180/2$ $b = 795\text{mm}$</p>
<p>Edgewise Elbow</p> 	<p>$\alpha = A - 115\text{mm} - 75\text{mm}$</p> <p>$b = B - 115\text{mm} - 75\text{mm}$</p> <p>Example: $\alpha = 800\text{mm}$, B=1000mm</p> <p>$\alpha = 800 - 115 - 75$ $\alpha = 610$</p> <p>$b = 1000 - 115 - 75$ $b = 810$</p>

ILLUSTRATIONS OF LINKK BUSDUCT TRUNKING SYSTEM

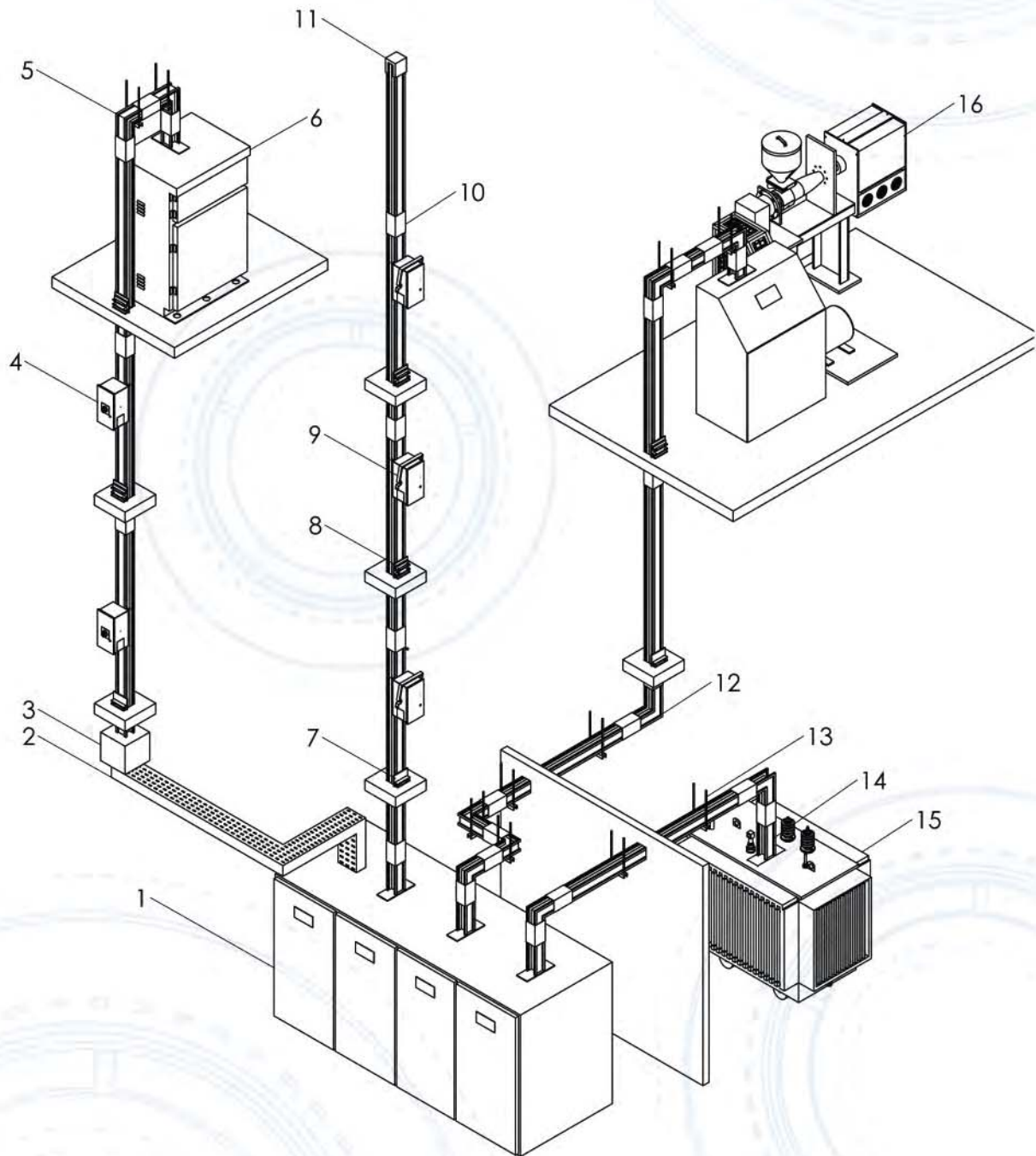

1. Main Switch Board
2. Cable Tray
3. End Feed Cable Box
4. Tap-Off Unit (Rotary Design)
5. Flatwise Elbow
6. Sub Switch Board
7. Vertical Fixed Support
8. Vertical Spring Support

9. Tap-Off Unit (Handle Design)
10. Joint
11. End Cover
12. Edgewise Elbow
13. Horizontal Support
14. Flange End
15. Transformer
16. Machine

INSTALLATION

Step 01

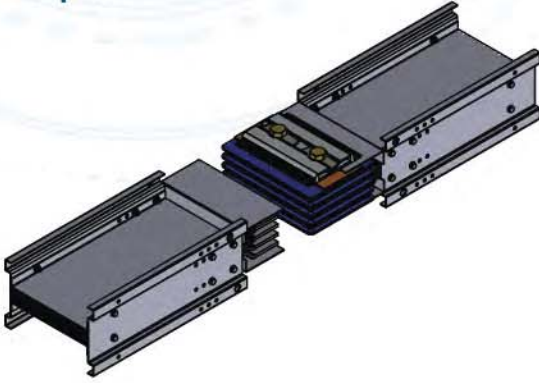

Step 02

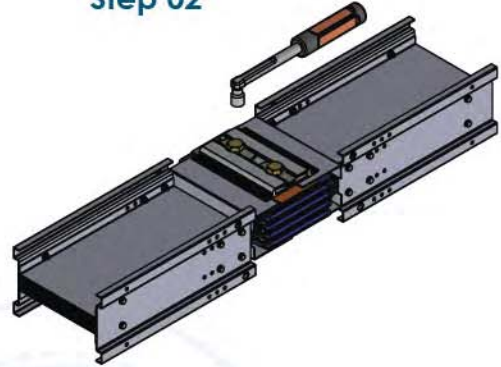

Step 03

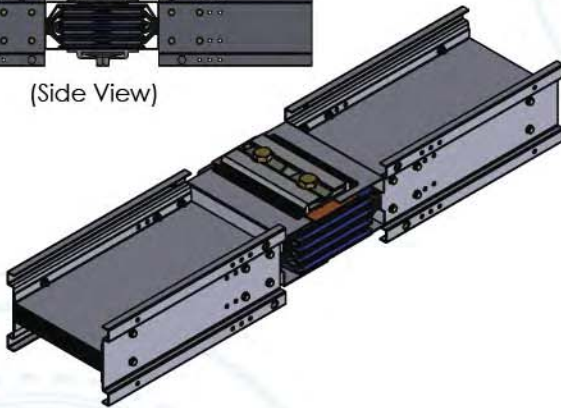

Step 04

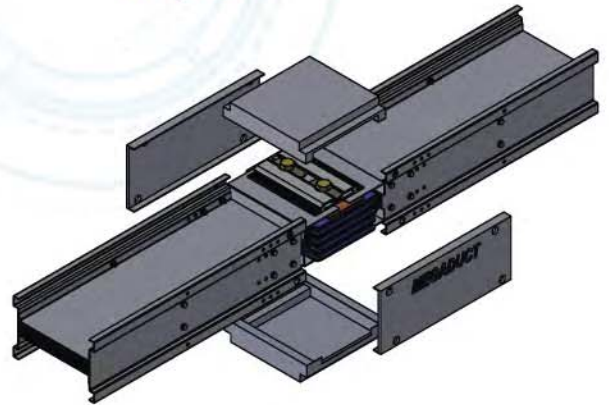

Step 05

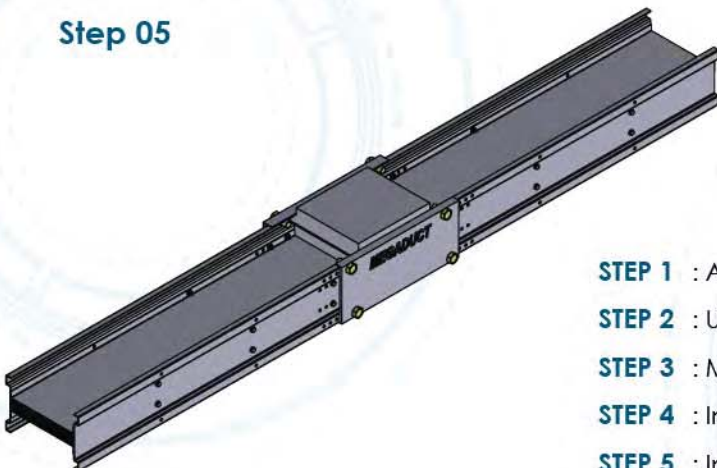

- STEP 1** : Align busduct with joint properly. Push busduct into joint.
- STEP 2** : Use torque wrench to tighten for about 70~75Nm.
- STEP 3** : Make sure busduct and joint are aligned properly.
- STEP 4** : Insert joint cover and joint side cover on the joint system.
- STEP 5** : Insert and fasten joint cover bolt.

GENERAL PRECAUTION

Storage

1. Verify the type and quantity of all part of busduct from delivery order. Inspect whether any damage or scratch during transportation.
2. Keep away busduct from wet and moisture place. Cover with water proof material for extra protection of busduct.
3. Place the stack of busduct on top of 2 pieces of wood. Make sure busduct in horizontal position.
4. To prevent the joint of the busway from being soiled, wrap them with vinyl sheet until immediate installation.



Preparation & Installation

1. Ensure equipment are strong enough for lifting and transportation.
2. Thoroughly check the laying route of the busduct to ensure it free from any obstacle, heat source and water leakage.
3. The installation usually start by connecting busduct to the transformer or switchboard.
4. Ensure to check the description and identification of each piece before installing.
5. Remove dirt and dust at joint area before installing busduct joint.
6. Ensure to test insulation resistance by merger test. The test must be performed for every joint connection.

QUALITY CONTROL



Temperature Rise



Dielectric Test

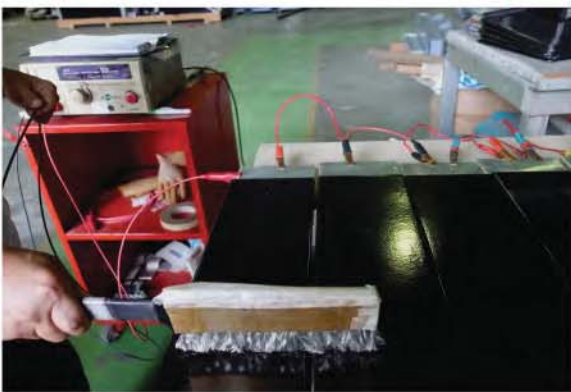

Pinhole Detector



Conductivity Test

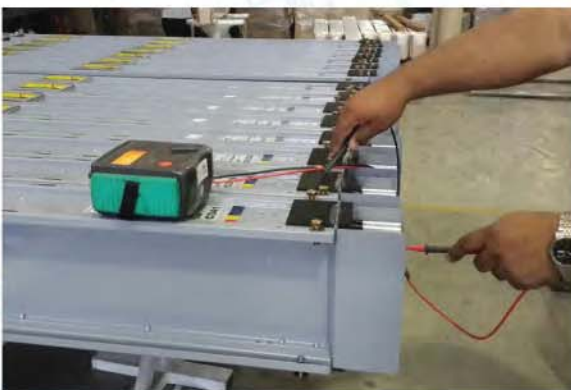

Megger Test



Epoxy Thickness Test

STANDARD & TESTING

LINKK provides a good structure short circuit protection design which had been certified by ASTA, KEMA & UL



LINKK Busduct is capable of carrying full rated current continuously in ambient condition of 95% relative humidity and also ambient temperature in 50°C.



Busduct design verification according to IEC 61439.

- | | | | |
|------|---|-------|-------------------------------------|
| 10.2 | Strength of material and parts. | 10.8 | Terminals for external conductors. |
| 10.3 | Degree of protection of enclosure. | 10.9 | Dielectric properties. |
| 10.4 | Clearance and creepage distances. | 10.10 | Verification of temperature-rise. |
| 10.5 | Protection against electric shock and integrity of protective circuits. | 10.11 | Short-circuit withstand strength. |
| 10.7 | Internal electrical circuit and connections. | 10.12 | Electromagnetic compatibility(EMC). |
| | | 10.13 | Mechanical operating. |

PROJECT REFERENCES

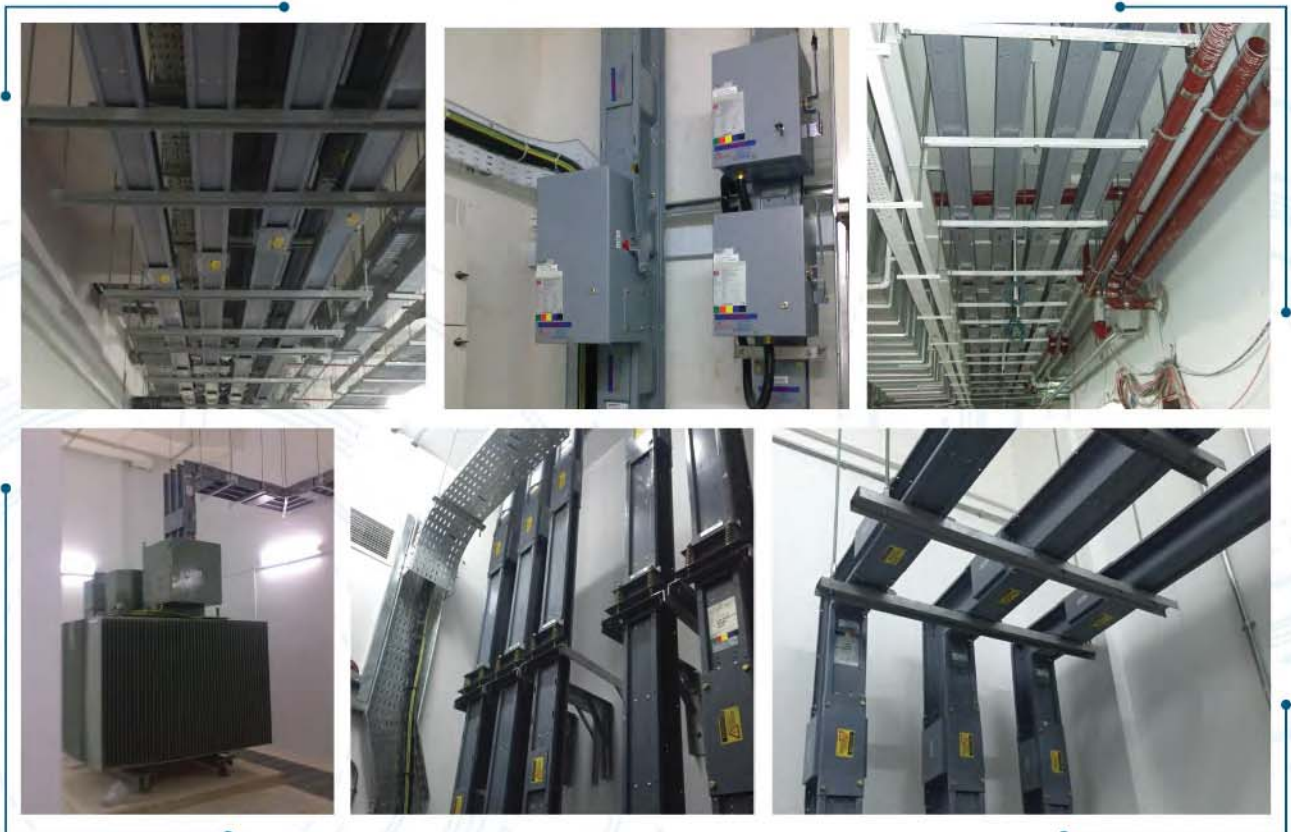

PROJECT REFERENCES

Residences



AEQUA Sukhumvit 49, Thailand



Marina Bay Central, UAE



Forest City, Malaysia



Binh Khanh, Vietnam

Hotels



Shangri-La Hotel, China



Langham Places, Hong Kong



1 Borneo, Malaysia



Conrad Hotel, Philippines

Commercial Complex / Business Premises



Oriental Plaza, Vietnam



Equity Tower, Indonesia



Saigon M&C Tower, Vietnam



Telekom Tower, Malaysia



Al Shoumoukh Tower, Qatar

Airport / High Speed Rail Station



Male International Airport, Maldives



MRT, Singapore



HSR Zuoying Station, Taiwan

PROJECT REFERENCES

Hospitals

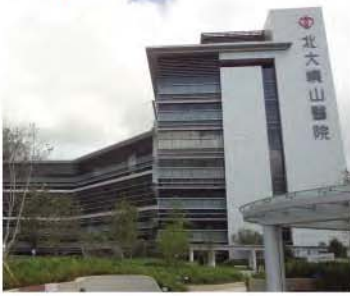

Lantau Hospital,
Hong Kong



Belfast City Hospital,
Northern Ireland



Bhumibol Adulyadej
Hospital, Thailand



Selayang Hospital,
Malaysia

Industries / Assembly Lines



Proton Factory, Shah Alam,
Malaysia



Perodua Assembly Plant,
Malaysia



Singpost Logistics Hub,
Singapore



Galtronics, Vietnam

Public Centres



Changi Prison,
Singapore



Garden By The Bay,
Singapore



Chiang Mai Convention
Centre, Thailand



Customs Headquarters
Building, Hong Kong

Information Technology



Microsoft Office, India



PCCW, Hong Kong



Vista Hub, Philippines

CONTINUOUS BUSDUCT MONITORING SYSTEMS

Continuous busduct monitoring system is a new technology provided by AP sensing which provided continuous temperature monitoring and automatically alarm abnormalities of busduct systems. It consists of Distribution Temperature Sensing(DTS), optic fibre cable and computer software. It could measure entire busduct system up to 10km. The advantage of this device are longer busduct lifespan, provided alarm system and prevention of fire due to abnormalities of busduct system.

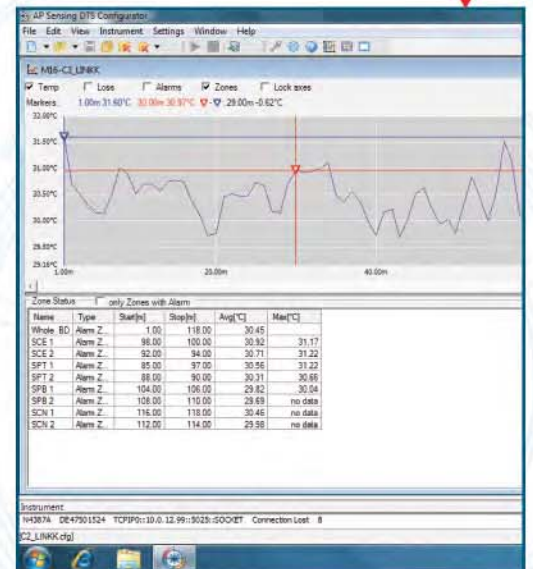
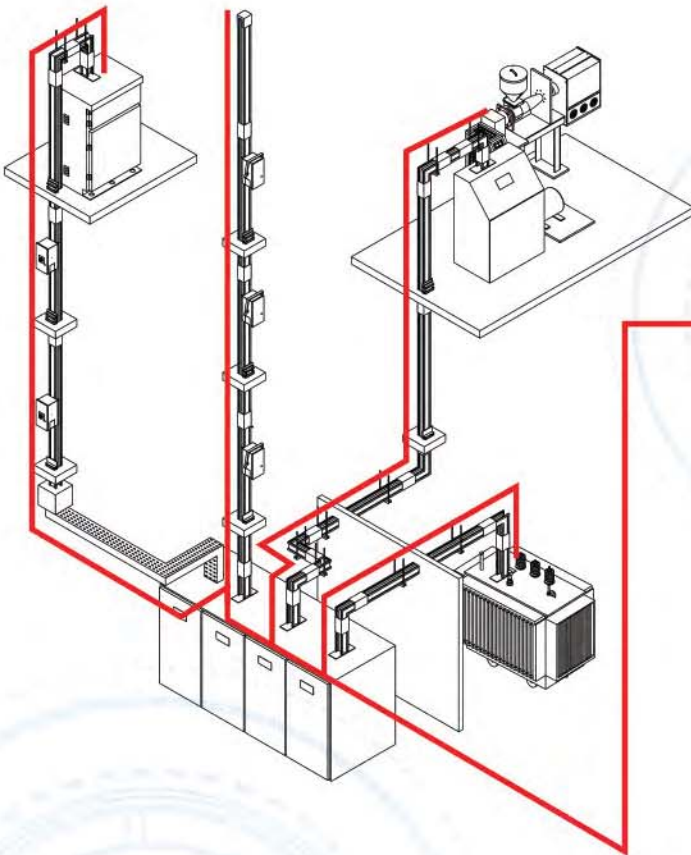

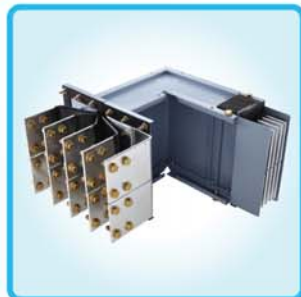

LINKK BUSWAY SYSTEMS (M) SDN BHD (1018052-D)

Lot 43117, Off Jalan Balakong, 43300 Balakong, Seri Kembangan,
Selangor Darul Ehsan, Malaysia
Tel: 603 - 8964 4080 Fax: 603 - 8961 8481
Email: customerservice@linkk.com.my / marketing@linkk.com.my
website: www.linkk.com.my

Sales & Marketing contact:

TIC MODULAR SYSTEM CO., LTD.
TIC ENGINEERING CO., LTD.
TIC ELECTRIC CORPORATION CO., LTD.

99/9 Moo 12 Puttamonthon 5 Road, Raising
Sampran, Nakhonpathom 73210 Thailand
Tel : +662 105 4247 Fax : +662 482 1620
www.ticcorp.net

OUR SIGNATURE PROJECT

Marina 101 Dubai is the tallest residential building in the world which is 426.5m (1399ft) tall. There are total 16 runs of busways (3400m) in the building from 1200A to 4000A. The skyscraper will have 5-star hotel, residential apartment and restaurant in the hotel tower. The 101st floor of the skyscraper will feature a club lounge, restaurant and merchandise store.

